

Lampiran 1

ANGKET

A. IDENTITAS RESPONDEN

Pelanggan Kukumama yang terhormat, Saya adalah mahasiswa Universitas Sangga Buana YPKP Fakultas Ilmu Sosial Dan Ilmu politik jurusan Administrasi Bisnis. Dalam rangka penyusunan tugas akhir (skripsi), bersama ini saya mohon bantuan Saudara/i bersedia menjadi responden dalam penelitian yang saya lakukan. Penelitian ini dilakukan dengan tujuan menganalisis pengaruh *relationship marketing* dan suasana kafe terhadap loyalitas pelanggan di Kukumama Bandung. Saya mohon bantuan Saudara/i untuk memberikan informasi dibawah ini. Isi pertanyaan atau berilah tanda ceklis pada kolom yang tersedia sesuai tanggapan Saudara/i dengan alternatif jawaban yang telah tersedia.

1. Jenis Kelamin
 Pria Wanita
2. Usia Anda:
 < 15 tahun 15-20 tahun
 20-25 tahun >25 tahun
3. Profesi : (pilih Salah satu pilihan dibawah ini)
 Pelajar/Mahasiswa
 Karyawan
4. Pendapatan perbulan dalam rupiah : (pilih salah satu pilihan di bawah ini)
 < 1 Juta
 1 juta - < 2 juta
 2 juta - < 3 juta
 3 juta - < 5 juta
 > 5 juta
5. Pengeluaran perbulan dalam rupiah: (Pilih sala satu pilihan di bawah ini)
 < 1 Juta
 1 juta - < 2 juta
 2 juta - < 3 juta
 3 juta - < 5juta
 > 5 juta
6. Pernah Lunch atau Dinner di Kukumama Bandung
 Ya Tidak

B. ANGKET PERNYATAAN

Pada Petunjuk pengisian : silahkan Anda pilih jawaban yang menurut Anda paling sesuai dengan kondisi yang ada dengan cara memberikan tanda (\surd) Pada pilihan yang tersedia dan diharapkan tidak ada jawaban yang kosong.

Keterangan :

5 = Sangat Setuju (SS)

3 = Ragu-Ragu (RG)

1 = Sangat Tidak Setuju

4 = Setuju (S)

2 = Tidak Setuju (TS)

No	Pernyataan	SS	S	RG	TS	STS
A. Relationship Marketing						
1	Kukumama konsisten dalam memberikan pelayanan yang berkualitas					
2	Karyawan kukumama menunjukkan rasa hormat kepada pelanggan					
3	Kukumama cafe & resto Bandung membuat penyesuaian untuk memenuhi kebutuhan pelanggan					
4	Kukumama cafe & resto Bandung fleksibel ketika terjadi perubahan pelayanan					
5	Kukumama Senantiasa aktif melakukan kontak dan memberikan informasi- informasi yang terkini dan dapat dipercaya kepada pelanggan baik secara langsung atau pun tidak langsung (melalui media sosial)					
6	Kukumama cafe & resto Bandung memberikan informasi ketika terdapat layanan terbaru					
7	Karyawan Kukumama cafe & resto Bandung menjelaskan informasi yang ingin diketahui pelanggan					
8	Kukumama cafe & resto Bandung berusaha menyelesaikan konflik yang terjadi dalam pelayanan					
9	Kukumama cafe & resto Bandung memberikan tanggapan positif terhadap keluhan dan saran yang diterima.					
B. Suasana Kafe						
10	Papan nama atau Logo Kukumama cafe & resto Terlihat jelas dan menarik					
11	Kukumama cafe & resto memiliki fasilitas parkir yang aman					
12	Bangunan Kukumama cafe & resto menarik dan unik					
13	Kondisi ruangan Kukumama cafe & resto Bandung bersih dan mempunyai tema atau konsep ruangan menarik					
14	Pengaturan cahaya dalam cafe Kukumama sangat baik					

15	Aroma ruangan, suhu ruangan dan Musik yang dimainkan di Kukumama membuat saya merasa betah berada di dalamnya					
16	Penataan meja dan kursi di Kukumama cafe & resto tersusun dengan rapi					
17	Pengaturan rak barang bar & kitchen tampak rapi dan gang untuk berjalan dari satu tempat ke tempat lainnya memadai luasnya.					
18	Pemasangan tanda petunjuk di Kukumama Cafe & resto Bandung mempermudah saya dalam memahami petunjuk/peraturan yang ada di kukumama					
19	Hiasan dinding di dalam ruangan Kukumama Cafe & resto Bandung terlihat unik dan menarik					
C. Loyalitas Pelanggan						
20	Saya akan makan dan minum kembali di Kukumama Cafe & resto Bandung					
21	Saya bersedia membeli makanan dan minuman yang lain yang belum pernah saya pesan di Kukumama Cafe & resto Bandung					
22	Saya akan merekomendasikan kepada orang lain untuk makan dan minum di Kukumama Cafe & resto Bandung					
23	Saya memberitahuakan keunggulan Kukumama Cafe & resto Bandung kepada orang lain					
24	Saya tetap rutin berkunjung dan melakukan pembelian di Kukumama walaupun terdapat cafe-cafe lainnya					
25	Bila ada kekurangan pada Kukumama Cafe & resto Bandung, saya tidak akan langsung beralih ke cafe lain.					

Lampiran 2

Tabulasi Data Ordinal

No	X1 .1	X1 .2	X1 .3	X1 .4	X1 .5	X1 .6	X1 .7	X1 .8	X1 .9	X2 .1	X2 .2	X2 .3	X2 .4	X2 .5	X2 .6	X2 .7	X2 .8	X2 .9	X2 10	Y 1	Y 2	Y 3	Y 4	Y 5	Y 6
1	4	4	3	5	4	4	5	5	5	4	4	5	5	4	4	4	3	4	4	4	4	4	5	4	
2	4	5	4	5	4	5	4	5	5	5	5	5	5	5	4	4	3	4	4	5	5	4	4	4	4
3	3	3	5	4	4	4	4	4	4	5	5	5	5	4	5	5	3	3	4	4	4	5	5	4	4
4	4	4	4	4	4	4	3	4	4	4	4	5	5	5	4	3	1	2	4	4	4	3	3	4	3
5	3	4	3	3	4	2	4	2	2	4	4	4	5	4	3	3	2	3	3	3	3	3	3	4	4
6	4	4	2	4	4	3	3	4	4	4	4	4	4	4	4	3	2	2	3	4	3	3	3	3	3
7	3	4	4	4	4	3	3	3	3	4	3	4	4	4	3	4	2	3	3	1	3	3	3	3	3
8	4	4	3	3	4	3	5	3	3	4	4	5	5	4	2	2	1	3	3	4	4	4	4	4	4
9	3	3	3	4	4	5	5	4	4	5	5	5	5	5	4	4	3	4	4	4	4	4	4	4	4
10	5	3	5	5	5	5	5	5	5	5	5	5	5	5	5	4	4	5	5	5	5	5	5	5	5
11	2	3	3	3	3	3	3	3	3	3	3	4	4	4	3	3	2	4	3	5	5	5	5	5	5
12	2	4	5	4	3	4	4	4	3	5	5	5	5	4	4	4	3	4	4	4	4	4	4	4	4
13	5	4	4	5	4	5	3	5	5	5	5	5	5	5	3	4	2	5	5	4	4	4	4	4	4
14	5	4	5	5	5	3	3	5	5	3	3	3	5	5	5	3	2	3	3	4	4	3	4	4	4
15	5	4	4	4	4	4	4	4	4	4	4	4	3	3	3	3	2	2	2	2	3	3	4	4	4
16	5	4	4	4	4	4	4	5	4	4	4	3	4	4	4	3	3	4	4	4	4	4	4	4	4
17	5	4	3	5	5	4	4	4	4	4	4	4	4	4	4	4	1	3	3	3	3	3	3	3	3
18	3	4	5	5	5	4	5	5	4	4	4	4	4	5	5	5	5	4	4	3	3	3	3	3	3
19	5	4	5	4	4	4	4	4	4	4	4	4	4	4	4	5	3	4	4	4	4	4	4	4	3
20	3	3	2	3	3	3	3	3	3	4	4	3	2	3	2	4	1	1	1	2	1	2	4	4	4
21	5	3	3	5	5	3	3	3	3	4	4	5	5	5	3	2	2	3	2	3	4	3	4	4	4
22	5	3	4	4	4	4	4	4	4	5	5	5	5	4	4	4	3	4	4	4	4	4	4	4	4
23	4	3	3	5	5	5	5	5	5	2	2	3	1	2	5	3	1	1	3	3	3	3	4	5	4
24	5	3	5	5	5	5	5	5	5	4	4	4	5	4	5	5	4	4	3	4	4	4	5	4	4

25	3	3	3	3	4	4	3	4	4	4	4	5	4	4	3	4	3	3	4	4	4	4	4	4	
26	4	3	5	5	5	5	5	5	5	5	5	5	5	4	3	4	4	4	4	4	3	3	3	3	
27	5	3	5	5	5	3	3	2	2	5	4	4	5	4	5	3	5	5	4	4	4	4	4	4	
28	4	5	5	5	4	3	3	4	4	4	3	4	4	3	4	3	2	4	4	3	3	4	4	4	
29	3	4	3	4	4	3	2	2	2	4	4	4	4	4	3	3	2	2	3	3	3	4	4	4	
30	5	4	4	4	5	3	3	3	3	4	4	3	3	4	4	3	2	3	3	4	2	4	4	5	
31	5	4	4	4	4	4	3	3	3	4	4	3	3	4	4	4	2	2	2	4	4	4	4	5	
32	5	3	4	4	4	4	4	4	4	5	5	5	5	4	4	4	3	4	4	4	4	4	5	4	2
33	4	3	3	5	5	5	5	5	5	2	2	3	1	2	5	3	1	1	3	3	3	3	4	5	4
34	5	4	5	5	5	5	5	5	5	4	4	4	5	4	5	5	4	4	3	4	4	4	5	4	5
35	3	4	3	3	4	4	3	4	4	4	4	5	4	4	3	4	3	3	4	4	4	4	4	4	5
36	4	4	5	5	5	5	5	5	5	5	5	5	5	4	3	4	4	4	4	4	4	4	5	5	3
37	5	3	3	5	4	4	4	4	5	4	4	4	4	3	4	4	3	4	3	4	4	4	4	4	4
38	4	3	4	4	4	4	4	4	4	4	1	1	1	4	3	1	3	2	1	4	4	4	4	4	4
39	4	3	5	4	5	4	4	4	4	4	4	4	4	5	4	4	3	3	3	4	4	4	4	4	4
40	5	3	4	5	5	5	5	5	5	5	5	5	5	5	5	5	4	5	5	5	5	5	4	4	4
41	4	3	4	4	4	5	5	5	4	5	5	4	4	5	4	4	4	4	4	4	3	4	4	4	4
42	5	3	1	5	5	4	3	5	4	5	5	5	5	5	4	3	2	3	3	5	4	4	3	3	3
43	3	3	3	3	3	3	3	3	3	4	4	3	5	4	4	4	3	3	3	3	3	3	3	3	3
44	5	3	5	5	4	5	4	5	4	5	5	5	5	5	4	5	1	2	5	3	3	3	3	4	4
45	5	3	4	4	5	4	4	4	5	5	5	5	5	5	4	4	3	3	4	4	4	4	4	4	4
46	4	3	4	5	4	4	3	4	4	5	5	5	5	4	5	5	3	3	5	4	4	4	4	4	4
47	4	4	4	4	4	4	4	4	4	2	2	2	2	4	3	2	3	2	1	4	4	4	4	4	4
48	5	4	4	5	5	4	4	5	5	5	5	5	5	5	5	4	5	5	5	5	3	3	3	3	3
49	5	4	5	5	5	3	3	5	5	5	5	5	5	5	5	5	4	4	4	3	3	3	3	3	3
50	5	3	5	5	5	4	3	5	5	4	4	4	4	4	4	3	3	3	3	4	4	4	4	4	4
51	4	3	5	4	3	4	3	4	4	3	3	4	4	4	4	3	3	3	3	2	2	2	2	2	2
52	3	3	1	3	5	3	3	3	3	4	4	4	4	4	3	4	1	3	3	2	2	2	2	2	2
53	4	2	4	4	4	4	4	4	4	4	4	4	4	5	4	5	3	4	4	4	4	4	4	2	2
54	5	3	4	5	5	3	3	4	4	5	5	5	4	4	4	3	3	3	3	4	4	4	3	3	3
55	5	4	5	5	4	5	4	4	5	5	5	5	5	5	5	5	2	5	5	5	5	5	5	5	5
56	5	3	5	5	5	4	5	5	5	5	5	5	5	5	5	5	3	3	5	3	5	5	5	5	5

57	5	3	2	4	3	4	2	2	2	4	4	5	4	3	2	2	1	5	4	3	3	2	2	4	4
58	5	3	5	5	4	4	5	4	5	5	4	5	5	4	4	5	3	4	4	4	4	4	4	4	4
59	5	3	5	4	5	4	4	5	5	5	4	4	3	5	5	5	4	4	5	5	4	4	4	2	2
60	5	3	5	5	5	4	4	4	5	5	4	5	3	5	4	5	4	4	5	4	4	4	4	4	4
61	5	4	5	4	4	5	5	5	5	5	4	4	3	5	5	5	4	4	5	4	4	4	5	5	5
62	5	4	5	5	5	4	4	5	5	5	4	5	3	5	4	4	4	4	5	5	5	4	5	4	4
63	4	4	4	4	4	4	5	5	5	5	4	5	3	5	5	4	4	3	4	4	4	4	4	4	4
64	5	4	5	5	5	4	4	5	5	5	4	5	3	5	4	4	4	4	5	5	5	5	5	5	5
65	5	4	5	5	5	4	4	5	5	5	4	5	3	5	4	4	3	4	4	5	4	5	5	5	5
66	4	3	4	4	5	5	5	5	5	3	3	2	3	3	3	4	4	4	4	3	3	3	3	5	5
67	4	3	3	3	3	3	3	5	5	5	3	5	4	4	4	4	5	5	5	3	3	3	3	3	3
68	5	4	5	5	4	4	4	5	5	5	3	5	5	3	5	5	5	5	5	4	4	4	4	4	4
69	5	4	5	4	5	5	5	4	5	5	3	4	5	4	5	5	5	5	5	4	4	4	4	4	4
70	5	4	5	5	4	3	4	5	5	5	5	4	5	5	5	5	3	4	4	4	4	4	4	4	4
71	5	3	5	5	5	4	4	5	5	5	5	4	5	5	5	5	4	5	5	5	5	5	5	5	5
72	5	3	4	4	4	4	3	4	4	5	5	5	5	5	4	4	3	4	4	2	2	2	2	2	2
73	5	2	4	4	4	3	3	4	4	4	5	5	5	5	4	4	3	4	4	5	2	2	2	2	2
74	5	2	4	4	4	4	4	5	5	5	5	4	5	5	5	4	3	4	4	5	4	4	4	4	4
74	5	2	4	4	5	3	3	4	5	4	4	4	4	4	4	4	3	3	3	4	4	4	4	4	4
76	4	4	4	4	3	4	4	5	4	5	5	4	4	4	4	4	3	3	4	5	4	4	4	4	4
77	5	3	5	4	4	4	4	5	5	5	5	5	5	6	4	4	3	4	5	5	4	4	4	4	4
78	5	4	5	5	4	4	4	5	5	4	4	4	5	5	3	4	3	4	4	5	4	4	4	4	4
79	4	3	4	4	4	3	4	4	4	4	4	4	4	4	3	4	3	4	4	4	4	3	4	4	4
80	3	3	3	4	4	3	3	4	4	4	4	4	4	4	3	4	3	4	4	4	4	3	4	4	4
81	4	3	4	4	4	3	3	4	4	4	4	4	4	4	3	4	4	4	4	3	3	3	4	4	4
82	5	3	4	4	4	5	5	5	4	4	4	3	4	3	4	4	4	4	3	3	3	2	4	4	4
83	5	3	5	5	5	3	4	4	5	4	4	5	4	4	4	4	3	4	4	5	4	5	4	4	4
84	4	3	4	4	4	3	2	4	3	4	4	4	5	4	3	4	3	2	4	3	3	3	3	3	4
85	5	3	4	5	4	4	5	5	5	4	4	5	4	4	4	5	4	4	4	5	3	3	3	3	4
86	4	3	4	4	4	3	4	4	4	4	4	4	4	4	4	4	3	4	4	4	4	4	3	3	3
87	4	3	4	4	4	3	4	4	4	4	4	5	4	5	5	5	4	5	5	5	4	4	4	5	5
88	5	3	4	4	4	4	4	2	2	5	5	5	5	4	4	4	5	5	4	4	5	5	5	5	5

89	5	3	4	4	4	4	3	4	4	4	4	4	4	4	4	3	4	4	4	4	4	4	4	4
90	5	3	4	4	4	5	4	5	5	4	4	4	4	4	4	4	3	4	5	3	4	3	4	4
91	5	4	4	4	4	3	3	4	4	5	5	4	4	4	4	4	4	4	3	3	3	3	3	3
92	5	4	5	4	4	3	4	4	4	5	5	4	4	4	4	3	4	5	5	3	3	3	3	3
93	4	4	4	4	4	4	4	4	4	4	4	4	4	4	4	4	3	4	4	5	4	4	4	3
94	4	4	4	4	4	3	3	4	4	4	4	4	4	4	4	5	4	4	4	5	4	4	4	4
95	5	3	4	4	4	4	4	4	5	4	4	4	4	4	4	3	4	4	4	5	4	4	4	4
96	4	2	4	4	3	3	4	4	4	4	4	4	4	4	5	4	4	4	3	4	4	5	4	4
97	4	4	4	4	3	4	3	4	4	4	4	4	4	4	3	4	3	4	4	4	4	4	4	4
98	4	4	4	4	3	3	4	3	4	4	4	4	5	5	3	5	3	4	5	4	4	4	4	4
99	4	4	3	4	3	4	4	4	4	4	4	4	5	4	3	4	3	4	4	4	4	3	3	4
100	4	3	4	5	4	4	3	4	5	5	5	4	4	4	4	4	3	4	4	3	3	2	3	3
101	4	3	3	4	4	3	3	4	4	4	4	3	3	3	4	4	3	4	4	4	3	3	3	3
102	3	3	4	2	2	3	3	4	4	4	3	4	1	1	4	4	2	2	1	2	1	1	3	2

Lampiran 3

Hasil Tabulasi Data SmartPLS 3.0

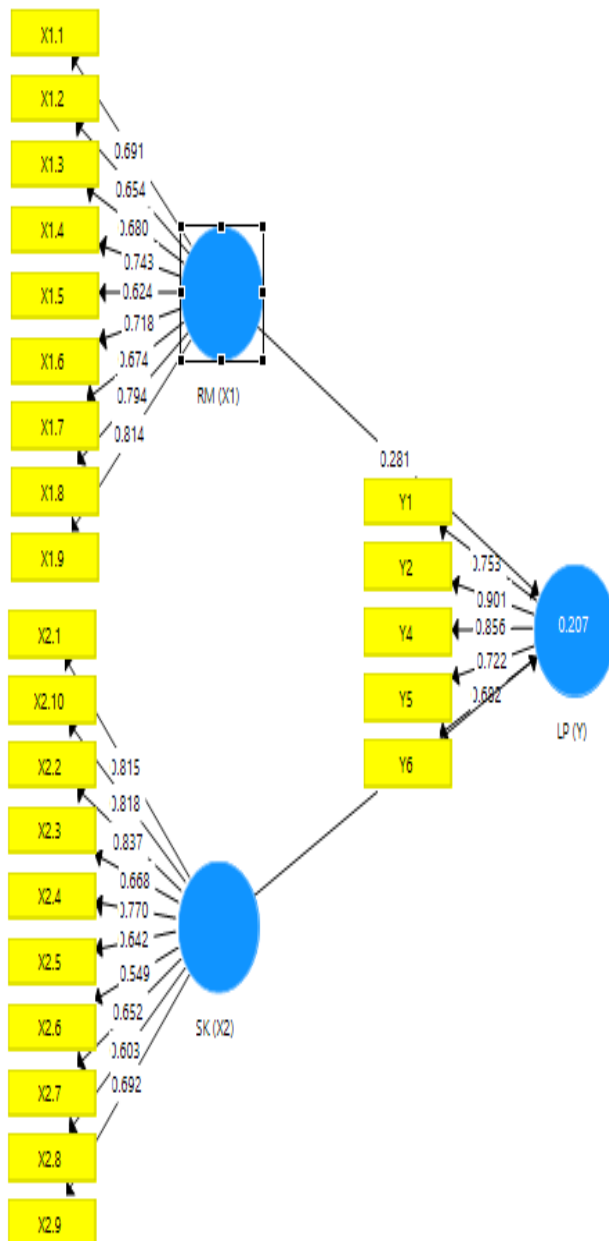

Lampiran 4 Hasil Output Smart PLS 3.2.1

COMPOSITE RELIABILITY

Composite Reliability

Mean, STDEV, T-Values, P-Values... Confidence Intervals Confidence Intervals Bias C... Samples Copy to Clipboard: Excel Format R Format

	Original Sampl...	Sample Mean (...)	Standard Devia...	T Statistics (O...	P Values
LP (Y)	0.913	0.907	0.040	23.120	0.000
RM (X1)	0.902	0.898	0.021	42.702	0.000
SK (X2)	0.910	0.907	0.012	72.863	0.000

Cronbach Alpha

rho_A

Mean, STDEV, T-Values, P-Values... Confidence Intervals Confidence Intervals Bias C... Samples Copy to Clipboard: Excel Format R Format

	Original Sampl...	Sample Mean (...)	Standard Devia...	T Statistics (O...	P Values
LP (Y)	0.929	0.920	0.046	20.381	0.000
RM (X1)	0.891	0.892	0.040	22.299	0.000
SK (X2)	0.890	0.896	0.029	30.757	0.000

R Square (R²)

	<i>R Square (R²)</i>	Kriteria
LP (Y)	0,312	Moderat

CROSS-VALIDATED REDUDANCY (Q²)

	SSO	SSE	Q² (=1-SSE/SSO)
RM (X1)	909,000	909,000	
SK (X2)	1,010,000	1,010,000	
LP (Y)	606,000	541,874	0,106

Hasil Pengujian Hipotesis

	Original Sample (O)	Sample Mean (M)	Standard Error (STERR)	T Statistics ((O/STERR))	P Values
RM (X1) ->LP(Y)	0,354	0,375	0,110	9,305	0,000
SK (X1) -> LP (Y)	0,268	0,281	0,116	2,311	0,011

Lampiran 5

Hasil uji F Anova

ANOVA^a

Model	Sum of Squares	Df	Mean Square	F	Sig.
1 Regression	270,463	2	235,231	54,667	,000 ^b
Residual	1255,116	99	12,678		
Total	1525,578	101			

a. Dependent Variable: Loyalitas Pelanggan (Y)

b. Predictors: (Constant), Suasana Kafe (X2), Relationship Marketing (X1)

Lampiran 6

Foto Dokumentasi Kukumama Bandung



